

Diamond_x AT_{1x} eLearning

Automotive Test Composite Pin
Course # 2001e

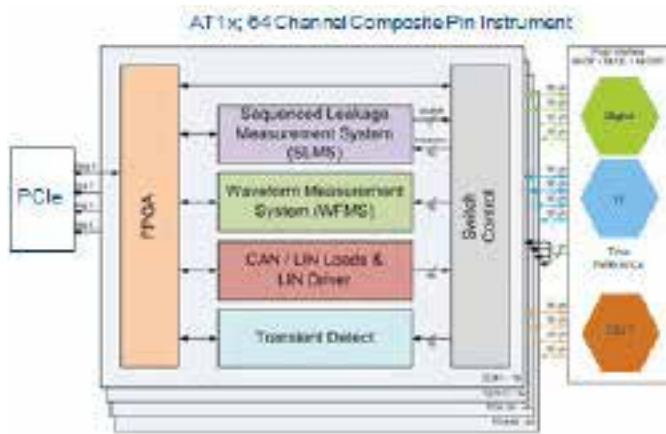

Automotive



Consumer



Flat Panel Display



IoT/loV & Optoelectronics



Industrial & Medical



MCU



Mobility

Course Description

This course introduces the student to the AT_{1x} instrument. The training will provide the student with an overview of the instrument, its theory of operation, and CAN and LIN Bus test programming examples. On completion of the course, the student will be able to describe the composite nature of the AT_{1x}, understand its theory of operation, add AT_{1x} instrument resources to a program, and be able to describe and complete programming statements and test methods used in test examples. This is accomplished by a combination of multimedia presentations and interactive software demonstrations.

Course Outline

- Product Overview
- Functionality and Theory of Operation
- Programming - Test Examples
- SLMS Programming
- CAN Bus Programming
- LIN Bus Programming

Course Length

- Self-paced – 5 hours typical depending on skill level

Prerequisites

- Six months test program experience
- Successful completion of Unison intro course

Recommended

- C or C++ programming
- Familiarity with Linux Operating System
- English - written and spoken

- 64 DUT Channels
- ± 100 V Sequence Leakage
- 28 V Waveform Measure / Driver
- ± 100 V Transient Detect System

Diamond_x AT_{1x} eLearning

Automotive Test Composite Pin

Course # 2001e

Course Modules

1 - Product Overview

This module is a foundation for the later modules, providing the student with an overview of the AT_{1x}. On completion of this module the student will be able to:

- State on which systems AT_{1x} can be installed
- Summarize benefits / capabilities of the AT_{1x}
- Recognize composite nature of instrument

2 - Functionality and Theory of Operation

This module provides an in-depth description of the AT_{1x} instrument functionality. Included in this module are functional block diagrams and illustrations meant to assist in understanding the operation of the instrument and its composite nature. On completion of this module the student will be able to:

- Identify and list the major functional areas
- Recall and list overall instrument capabilities
- List device diagnostics support
- Summarize key specs for each sub-system

3 - Programming – Test Examples

Designed to build on the student's existing knowledge of creating a Test Program in Unison, this section of the course consists of multiple programming modules and introduces the student to leakage, CAN Bus and LIN Bus programming using the AT_{1x}. These examples will be completed by the student in multiple stages using interactive software demonstrations to reinforce the programming concepts introduced. Throughout this section the student is encouraged to access the help system to develop familiarity with the programming statements. On completion of this module the student will be able to:

- Add AT_{1x} resources to an Adapter Board Object using the Unison Package Tool
- Recognize the features and benefits of the Unison Graphical Debug Tool (GDT)
- Recognize and use various Unison TMU, MATRIX and DIGITAL APIs in several API based test examples
- Complete a Single-shot Leakage Test (API)
- Complete a Sequenced Leakage Test (API)
- Complete a Leakage Test using the Unison Supplied Sequenced Leakage Test Method
- Complete CAN Bus TXD and RXD Timing Tests (API)
- Complete CAN Bus Tests using the Unison Supplied CAN Timing Test Method
- Complete LIN Bus RXD Timing Tests (API)
- Complete LIN Bus RXD Tests using the Unison-Supplied LIN Timing Test Method

At the end of each module the student will be required to pass a test, achieving a score of 75% or more. The student is encouraged to take notes throughout the course, and repeat, or pause the presentation as needed.

- 64 DUT Channels
- ± 100 V Sequence Leakage
- 28 V Waveform Measure / Driver
- ± 100 V Transient Detect System

Diamond_x AT1_x eLearning

Automotive Test Composite Pin
Course # 2001e

Who Should Attend

- Test program development engineers

Course Viewing Requirements

To view the course, you must have:

- Microsoft® Internet Explorer® 9.0 (or later), Mozilla®, Firefox®, or Chrome®
- Audio-listening capabilities
- Connection speed of at least 600 kbps

Course Cost

- Free of charge to all Diamondx and DxV Cohu customers